

## TECHNICAL DATA SHEET:

# EVOLUTION MkIV

The Evolution MkIV comes with a powerful submersible pump and AcquaSaver Mains/Rainwater switching device. Evolution MkIV is a simpler, more robust design with a slimline appearance.

When the rainwater tank runs out of water or when there's a power outage the AcquaSaver will automatically switch to mains supply for appliances.

Rainwater/mains supply changeover devices are a regular requirement for modern rainwater harvesting services, ensuring consistent water supply, and supporting water efficiency and stormwater management objectives.

The Acquasaver is designed to the Australian WaterMark Technical Standard Rainwater/mains supply changeover device WMTS-477:2016 LN 60075.

### RECOMMENDED FOR

- › Kingspan AQUAPLATE® Tanks domestic use

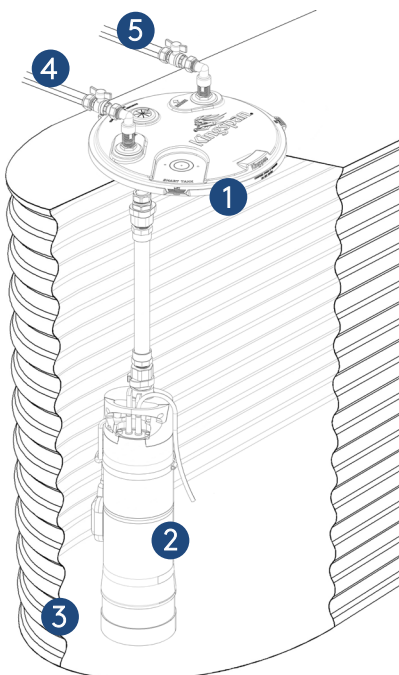

1. Evolution MkIV Head Unit
2. Grundfos SBA3-45A Submersible Pump  
(Includes 5m power cable)
3. Kingspan AQUAPLATE® Tank
4. Mains water inlet
5. Water outlet

### FEATURES & BENEFITS

- › 4 years warranty (2 years standard plus 2 years bonus when registering at [www.kingspanwatertanks.com.au](http://www.kingspanwatertanks.com.au)).
- › Quick and easy to install.
- › The small, lightweight unit fits neatly on top of the tank instead of the wall with a powerful and reliable submersible pump inside the rainwater tank.
- › Automatically switches to mains water when there is no water present in the tank or during electrical failure.
- › The design standard includes backflow protection.
- › Integrated float switch to prevent pump from running dry at low water levels.
- › The pump is only used when rainwater is being drawn from the tank, it does not operate when the Evolution MkIV unit is switched to mains water.
- › Automatic pump operation.
- › Submersible pumps are quieter than external pumps.
- › Corrosion resistant pump components.
- › Environmentally friendly - saves mains water, reduces flow to stormwater systems, no re-pumping of mains water.
- › Suitable for water tanks between 800mm to 2020mm high.

### MATERIAL, TYPES & SIZES

INLET/OUTLET	MATERIAL	TYPE & SIZE
Mains water inlet	Brass	Male G 3/4" (nut & olive)
Water outlet	Brass	Male G 3/4" (nut & olive)

## OPERATING CONDITIONS / TECHNICAL DATA

Grundfos SBA3-45A Pump

Supply Voltage	220 – 240 VAC
Rated Current	4.8A
Ambient temperature range	-10 to 50 °C
Max. Liquid temperature	40 °C
Min/Max. pressure	0-420 KPa
Cut in pressure	220 kPa
Max Flow Rate	106 litres/min
Approvals	AS/NZ 4020 – Testing of products for use in contact with drinking water

## PERFORMANCE

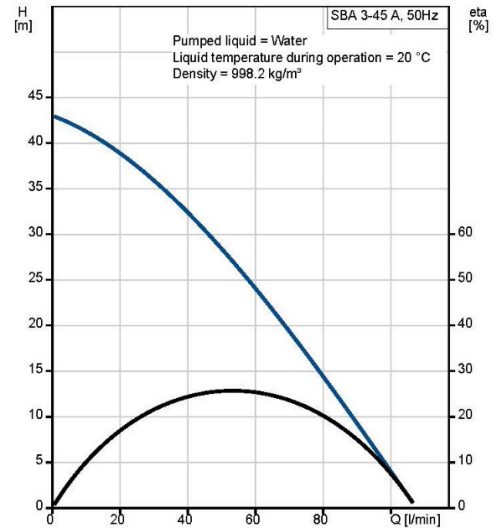

## DIMENSIONS

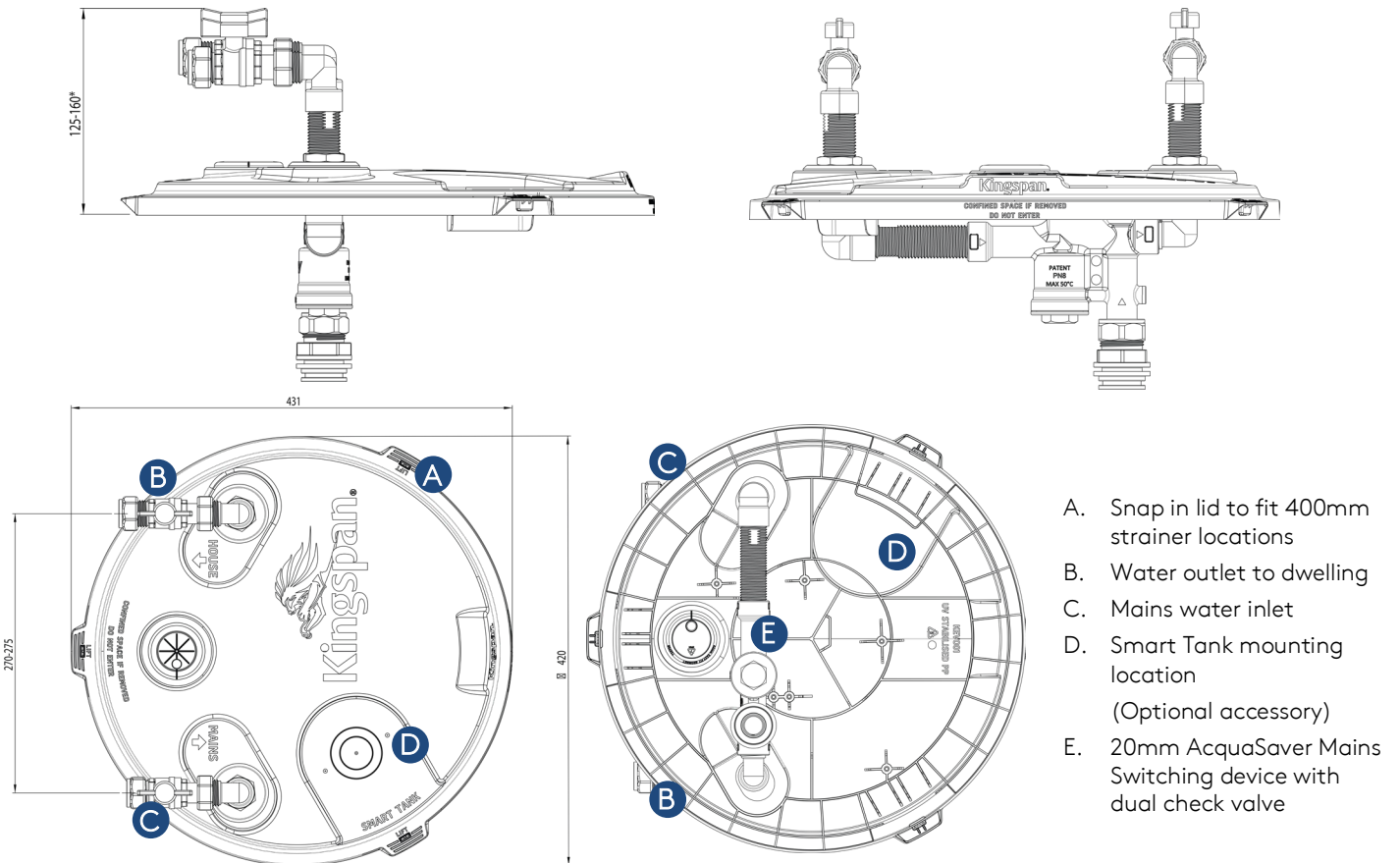

We take every care to ensure that the information in this document is accurate at the point of publication. Specification may vary (within a small parameter) due to manufacturing process variations or environmental conditions. All images are for illustration purposes only and should not be taken as binding. The actual product may vary, and specification/ dimensions/ colour/ other attributes may differ.

To ensure you are viewing the most recent and accurate product information, please visit this link: <https://www.kingspanwatertanks.com.au/evolution-mkiv-technical-sheet-Grundfos-SBA345A>

©Kingspan and the Lion Device are Registered Trademarks of the Kingspan Group plc in the UK, Ireland and other countries. All rights reserved.  
 Registered Office: Kingspan Water & Energy Pty Limited, 3 Herbert Place, Smithfield, NSW 2164

Kingspan Water & Energy Pty Limited

3 Herbert Pl Smithfield NSW 2164 | [kingspanwatertanks.com.au](http://kingspanwatertanks.com.au) | [sales.au@kingspan.com](mailto:sales.au@kingspan.com) | 1300 736 562  
 Evolution MkIV - Technical Sheet Grundfos SBA3-45A | V11 25/10/2022